

A-330

Turning AUTO REST®

**** Model A-330 can be ordered with LH or RH Side Mount Cylinder**

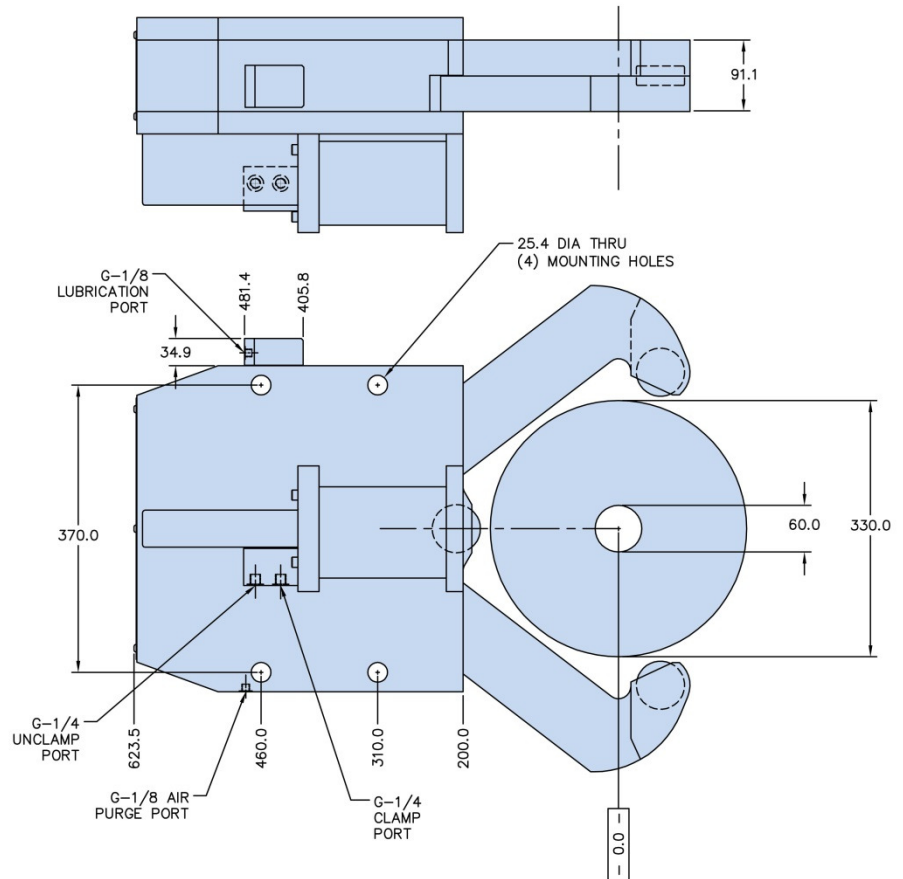
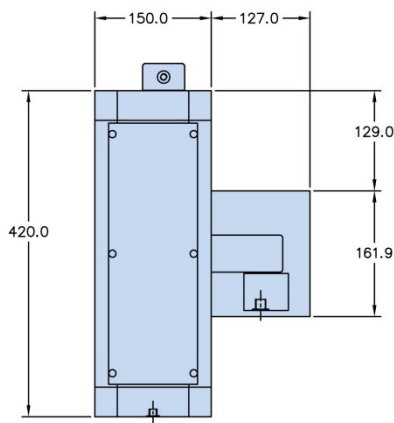

Maximum Clamp Size	mm	330
Minimum Clamp Size	mm	60
Max Workpiece Speed	Meters per Min	595
Max Lifting Capacity	kg	650
Piston Area	cm ²	69.7
Cylinder Stroke	mm	149
Operating Pressure	bar	10 - 40
Maximum Pressure	bar	40
Air Purge Pressure	bar	0.3 – 0.5
Lubrication Frequency		Working Cycle (or every 6 minutes)
Repeatability	mm	±0.010
Centering Accuracy	mm	±0.060
Mass	Kg	214

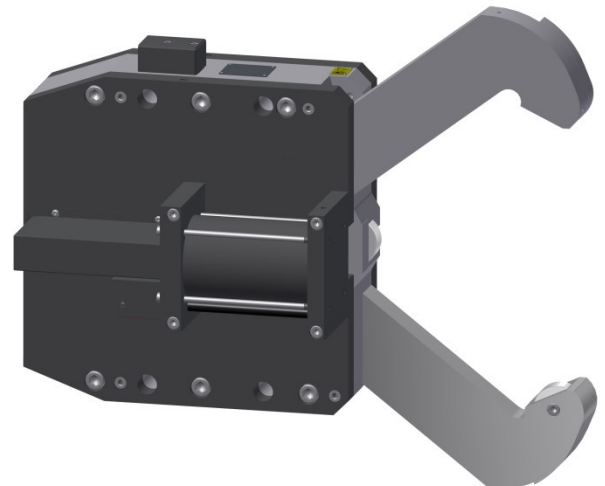

- Included Features:**
- * Hydraulic Operation
 - * Integrated Pilot Operated Safety Check Valve
 - * Side Mount Cylinder
 - * Oil Lubrication
 - * Air Purge

- Options:**
- * Manual Grease Lubrication
 - * Rear Mount Cylinder