

Grinding AUTO REST®

GC021042A

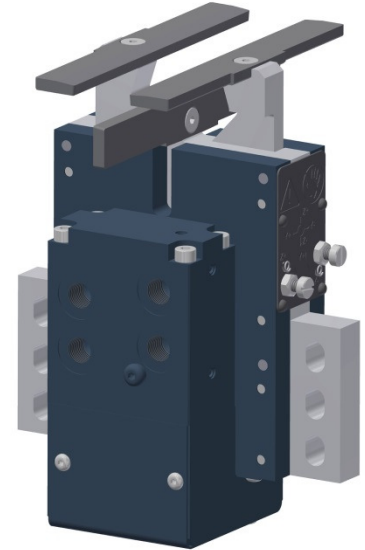
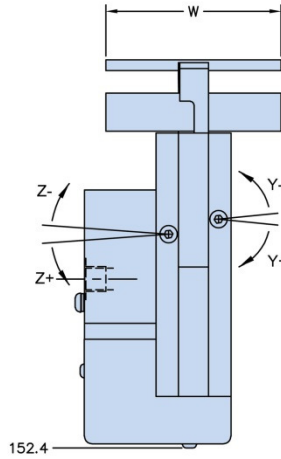
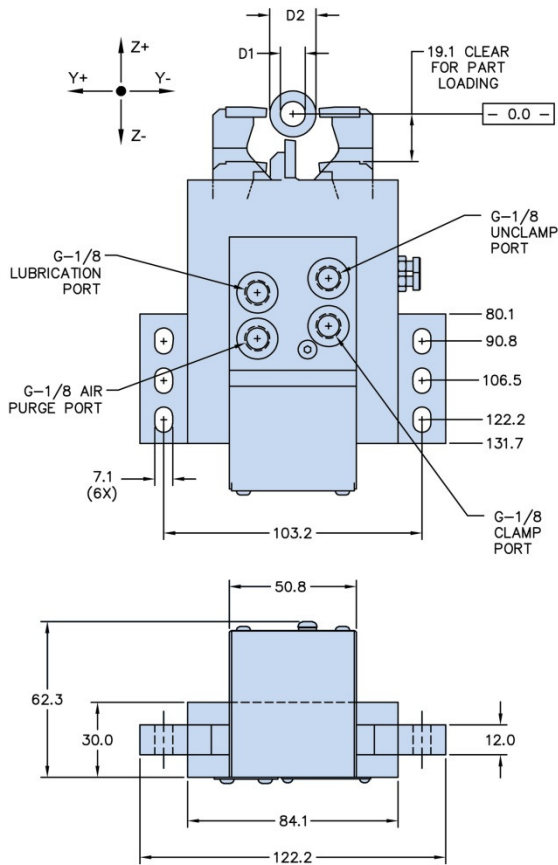

| Pad Set ** | | | 1 | 2 | 3 | 4 | 5 | 6 | 7 | 8 | 9 | 10 | 11 |
|------------------------|----|----|----|----|----|----|----|----|----|------|------|------|------|
| Minimum Clamp Diameter | D1 | mm | 1 | 2 | 3 | 3 | 3 | 3 | 3 | 10 | 10 | 10 | 18.5 |
| Maximum Clamp Diameter | D2 | mm | 2 | 4 | 10 | 10 | 10 | 10 | 10 | 18.5 | 18.5 | 18.5 | 26.5 |
| Width | W | mm | 50 | 50 | 10 | 15 | 25 | 45 | 82 | 40 | 70 | 108 | 170 |

| | | |
|-------------------------|-----------------|---------------------------------------|
| Z-Axis Adjustment Range | mm | ±0.13 |
| Y-Axis Adjustment Range | mm | ±0.08 |
| Piston Area | cm ² | 2.4 |
| Cylinder Stroke | mm | 29 |
| Operating Pressure | bar | 10 – 27 |
| Maximum Pressure | bar | 32 |
| Air Purge Pressure | bar | 0.3 – 0.5 |
| Lubrication Volume | cm ³ | 0.02 – 0.03 |
| Lubrication Frequency | | Working Cycle (or every 6 minutes) |
| Repeatability | mm | ±0.001 |
| Mass | kg | 4 |

** Contact sales@arobotech.com for pads not listed above

Included Features:
 * Arm Retraction For Part Loading
 * 2-Axis Centerline Adjustment
 * Side Mount Cylinder
 * Air Purge Port

Items Required To Use This Product:
 * Set of Wear Pads
 * Mounting Base