

Large O.D.

Grinding AUTO REST®

Contact sales@arobotech.com for full dimensional information of these models

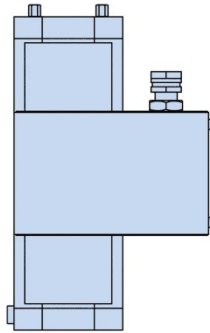
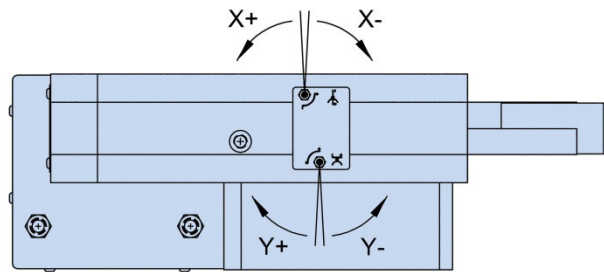

PROVISIONS FOR RETRACTED/
CLAMPED POSITION SENSORS
(12mm PROXIMITY SWITCH)

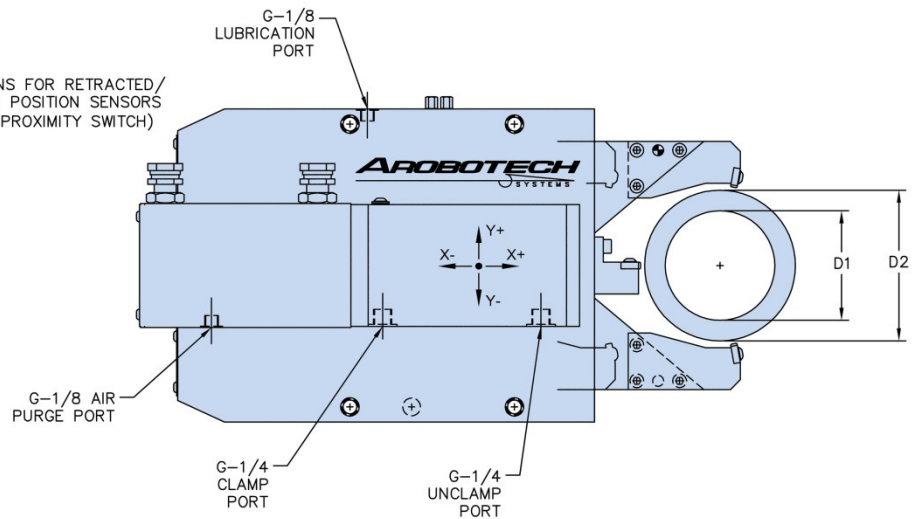

Model GC26345A

Nest Set			1	2	3
Minimum Clamp Diameter	D1	mm	30	60	90
Maximum Clamp Diameter	D2	mm	60	90	120

Model GC32363A

Nest Set			1	2	3
Minimum Clamp Diameter	D1	mm	30	70	110
Maximum Clamp Diameter	D2	mm	70	110	150

Model GC32615A

Nest Set			1	2	3
Minimum Clamp Diameter	D1	mm	30	90	150
Maximum Clamp Diameter	D2	mm	90	150	210

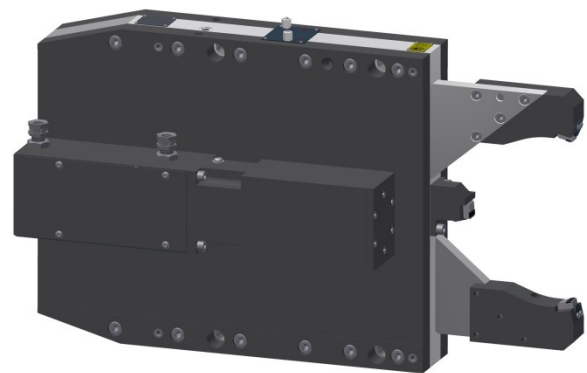

Contact sales@arobotech.com for full dimensional information of these models

Included Features:

- * Arm Retraction For Part Loading
- * Fixed or Follow Down Operation
- * 2-Axis Centerline Adjustment
- * Position Feedback Sensors
- * Visible Zero Adjustment Screws
- * Side Mount Cylinder

Items Required To Use This Product:

- * Set of Nests
- * Set of Wear Pads
- * Mounting Base