

Grinding AUTO REST® | GR-4100-000

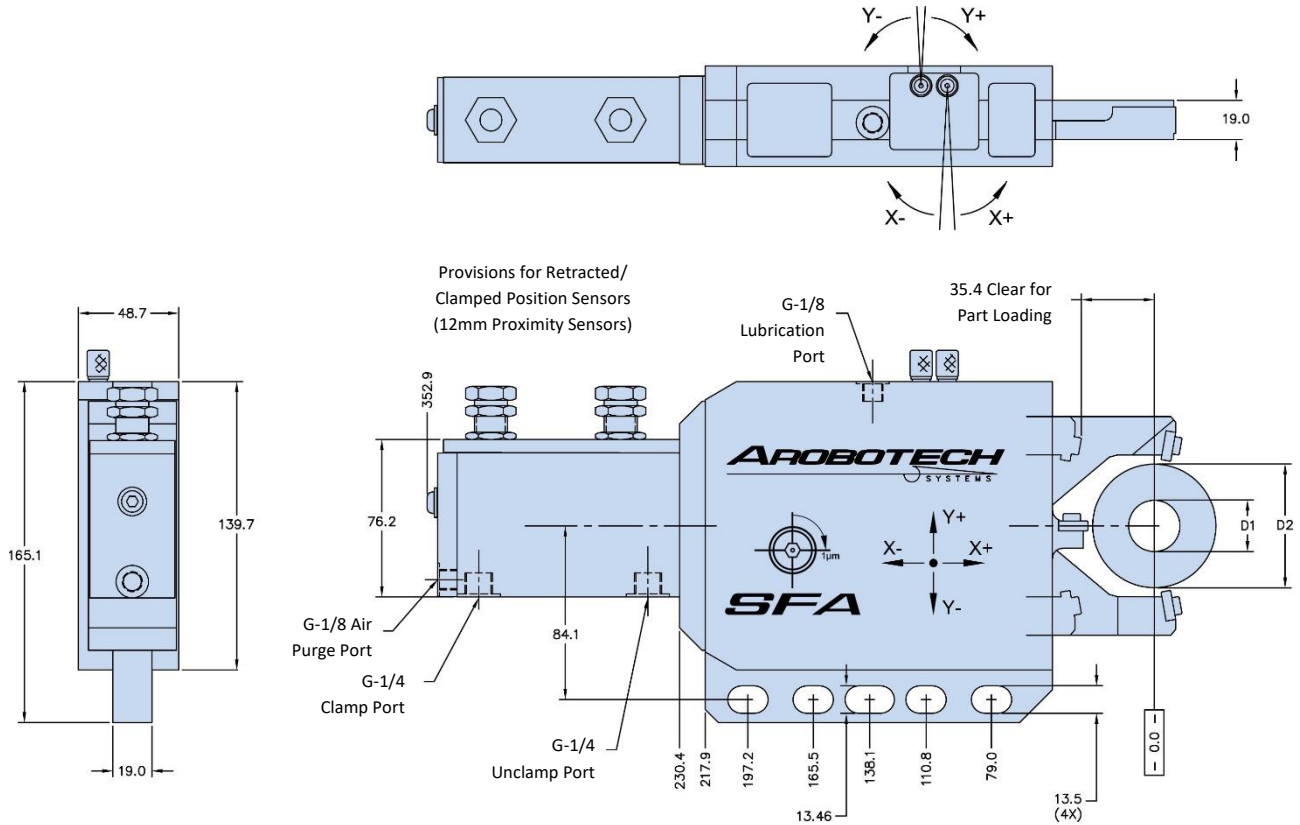

Wear Pad Set			1	2
Minimum Clamp Diameter	D1	mm	15	25
Maximum Clamp Diameter	D2	mm	50	60

X-Axis Adjustment per Screw Rotation	mm	0.004
X-Axis Adjustment Total	mm	±0.20
Y-Axis Adjustment per Screw Rotation	mm	0.004
Y-Axis Adjustment Total	mm	±0.20
Piston Area	cm ²	6.4
Cylinder Stroke	mm	69.5
Operating Pressure	bar	15 – 30
Maximum Pressure	bar	45
Air Purge Pressure	bar	0.3 – 0.5
Lubrication Volume	cm ³	0.04 – 0.06
Lubrication Frequency		Working Cycle (or every 6 minutes)
Repeatability	mm	±0.001
Mass	kg	11
Max Lifting Capacity	Kg	43

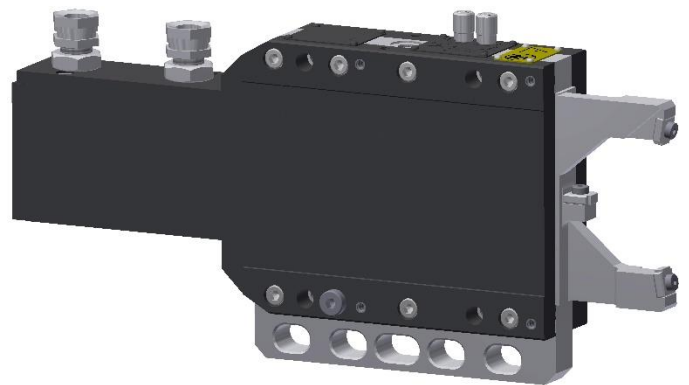

Included Features

- * Arm Retraction for Part Loading
- * Fixed or Follow Down Operation
- * 2-Axis Centerline Adjustment
- * 90° = 0.001mm Adjustment
- * Visible Zero Adjustment Screws
- * Position Feedback Sensors

Items Required To Use This Product:

- * Set of Wear Pads
- * Mounting Base

Contact Us For Full Technical Details And Customer Service

sales@arobotech.com

www.arobotech.com