

Contact sales@arobotech.com for full dimensional information of these models

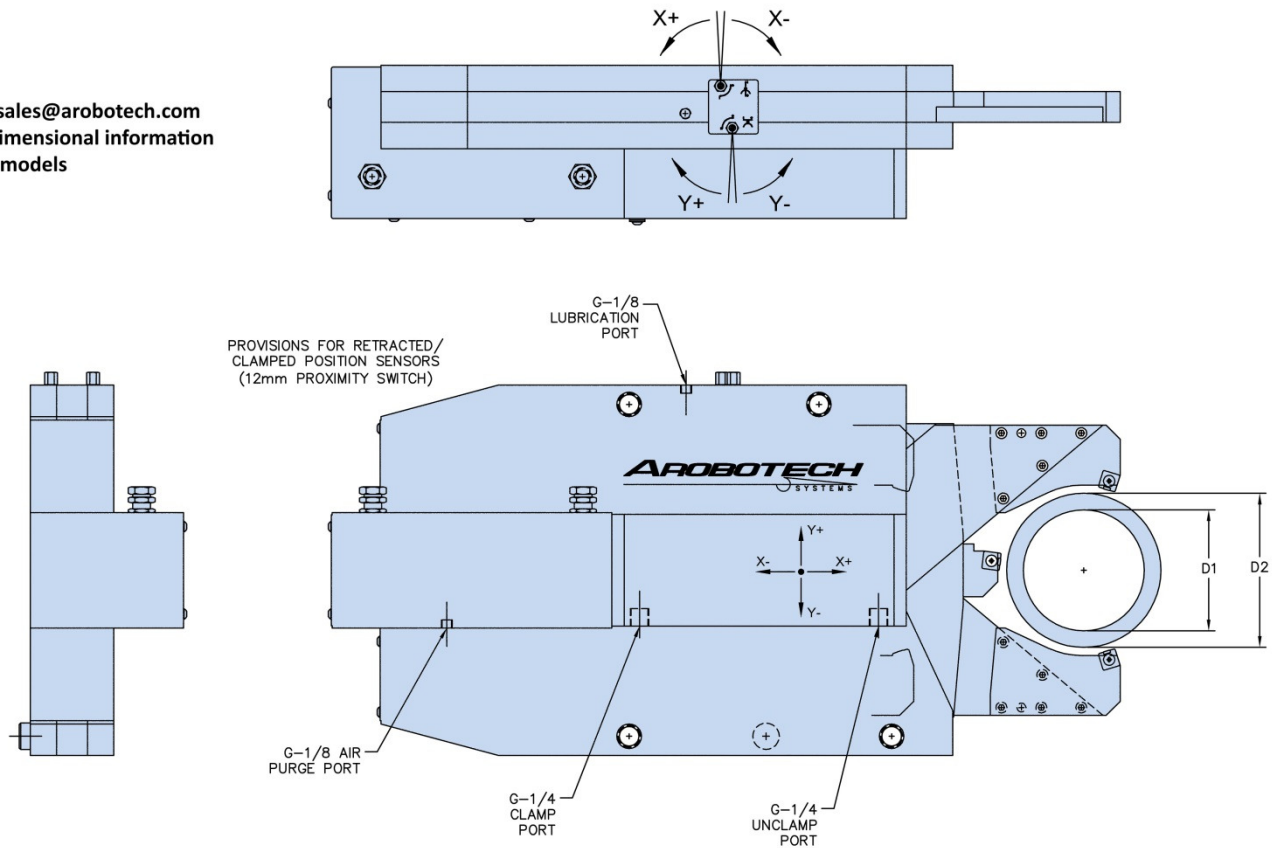

Model GC29036A

Pad Set			1	2	3
Minimum Clamp Diameter	D1	mm	60	90	120
Maximum Clamp Diameter	D2	mm	90	120	150

Model GC33679A

Pad Set			1	2	3
Minimum Clamp Diameter	D1	mm	80	120	160
Maximum Clamp Diameter	D2	mm	120	160	200

Contact sales@arobotech.com for full dimensional information of these models

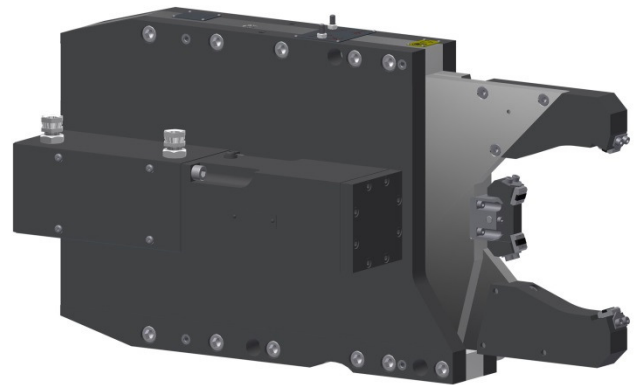

Included Features:

- * Arm Retraction For Part Loading
- * Extended Reach for C'Wt Clearance
- * Extended Clamping Range
- * Fixed or Follow Down Operation
- * Upper Arm Gage Clearance
- * 2-Axis Centerline Adjustment
- * Extended Adjustment Range
- * Visible Zero Adjustment Screws

Items Required To Use This Product:

- * Set(s) of Nests
- * Set of Wear Pads
- * Mounting Base