

GR-1150V-SDG

Grinding AUTO REST®

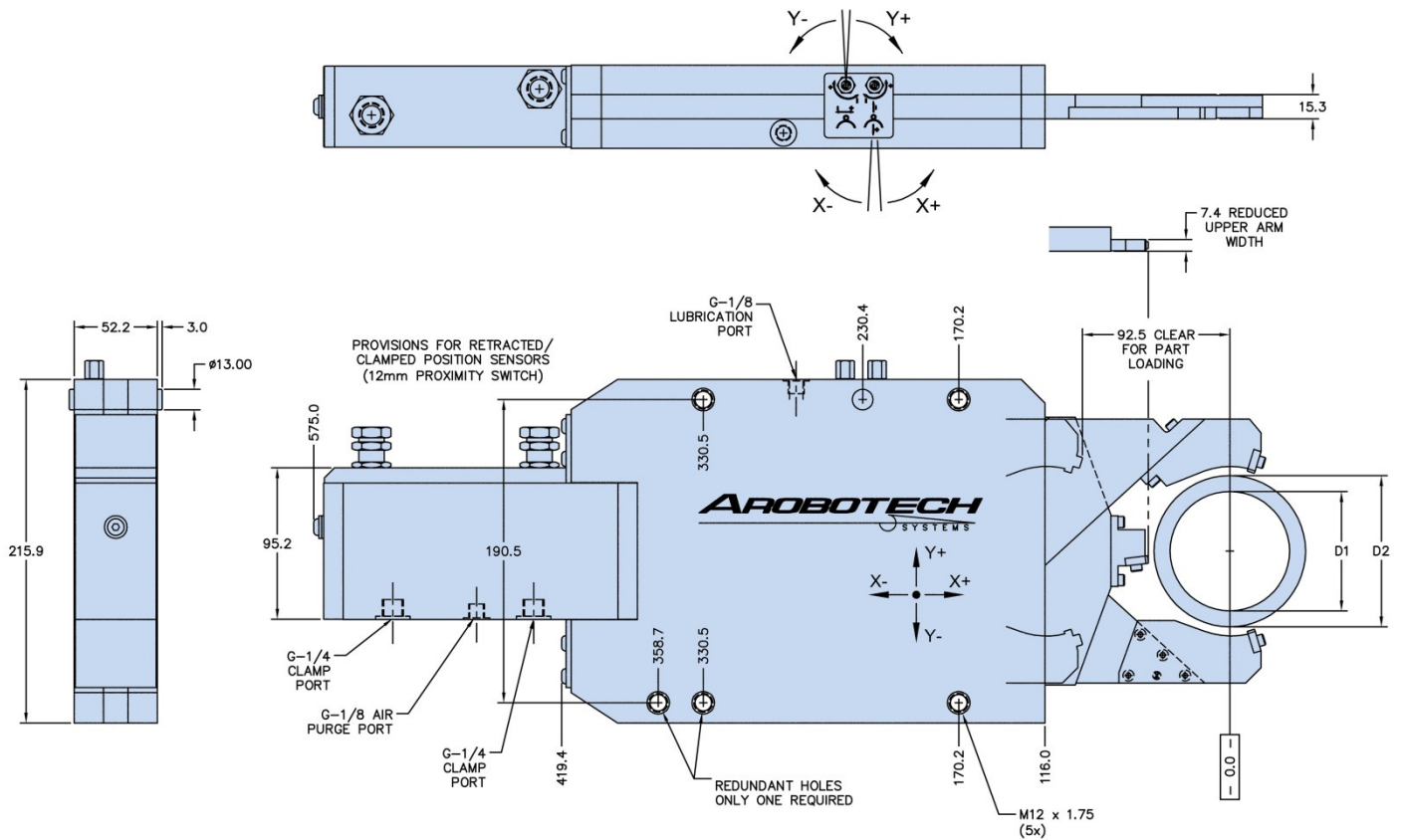

Nest Set			1	2	3	4
Minimum Clamp Diameter	D1	mm	15	35	55	75
Maximum Clamp Diameter	D2	mm	35	55	75	95

X-Axis Adjustment Range	mm	±0.28
Y-Axis Adjustment Range	mm	±0.50
Piston Area	cm ²	11.4
Cylinder Stroke	mm	127
Operating Pressure	bar	10 – 21
Maximum Pressure	bar	24
Air Purge Pressure	bar	0.3 – 0.5
Lubrication Volume	cm ³	0.10 – 0.15
Lubrication Frequency		Working Cycle (or every 6 minutes)
Repeatability	mm	±0.001
Mass	kg	32



Included Features:

- * Arm Retraction For Part Loading
- * Extended Reach for C'Wt Clearance
- * Fixed or Follow Down Operation
- * Upper Arm Gage Clearance
- * 2-Axis Centerline Adjustment
- * Position Feedback Sensors
- * Extended Adjustment Range
- * Visible Zero Adjustment Screws

Items Required To Use This Product:

- * Set(s) of Nests
- * Set of Wear Pads
- * Mounting Base