

GR-1000V-C

Grinding AUTO REST®

** Model GR-1000V-C can be ordered with LH or RH Side Mount Cylinder

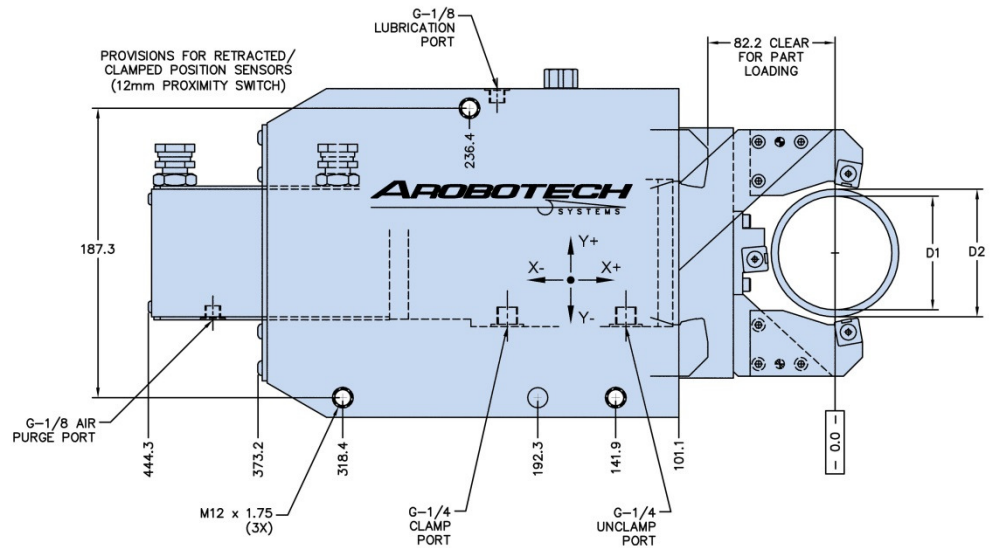
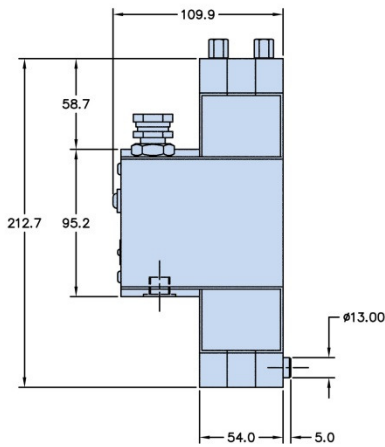
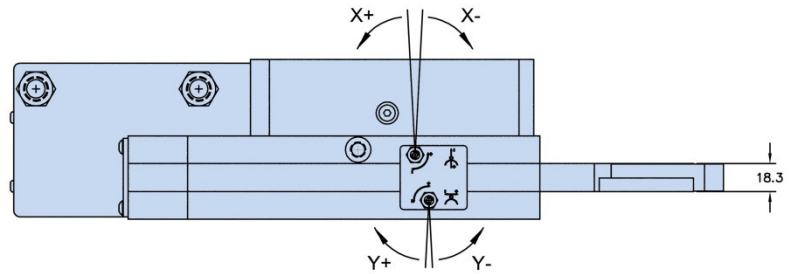

Nest Set			1	2	3	4	5
Minimum Clamp Diameter	D1	mm	42	50	58	66	74
Maximum Clamp Diameter	D2	mm	50	58	66	74	82

X-Axis Adjustment Range	mm	±0.22
Y-Axis Adjustment Range	mm	±0.07
Piston Area	cm ²	11.4
Cylinder Stroke	mm	108
Operating Pressure	bar	7 – 17
Maximum Pressure	bar	20
Air Purge Pressure	bar	0.3 – 0.5
Lubrication Volume	cm ³	0.10 – 0.15
Lubrication Frequency		Working Cycle (or every 6 minutes)
Repeatability	mm	±0.001
Mass	kg	29



Included Features:

- * Arm Retraction For Part Loading
- * Extended Reach for C'Wt Clearance
- * Fixed or Follow Down Operation
- * 2-Axis Centerline Adjustment
- * Position Feedback Sensors
- * Visible Zero Adjustment Screws
- * Side Mount Cylinder

Items Required To Use This Product:

- * Set(s) of Nests
- * Set of Wear Pads
- * Mounting Base