

GR-6030V

Grinding AUTO REST®

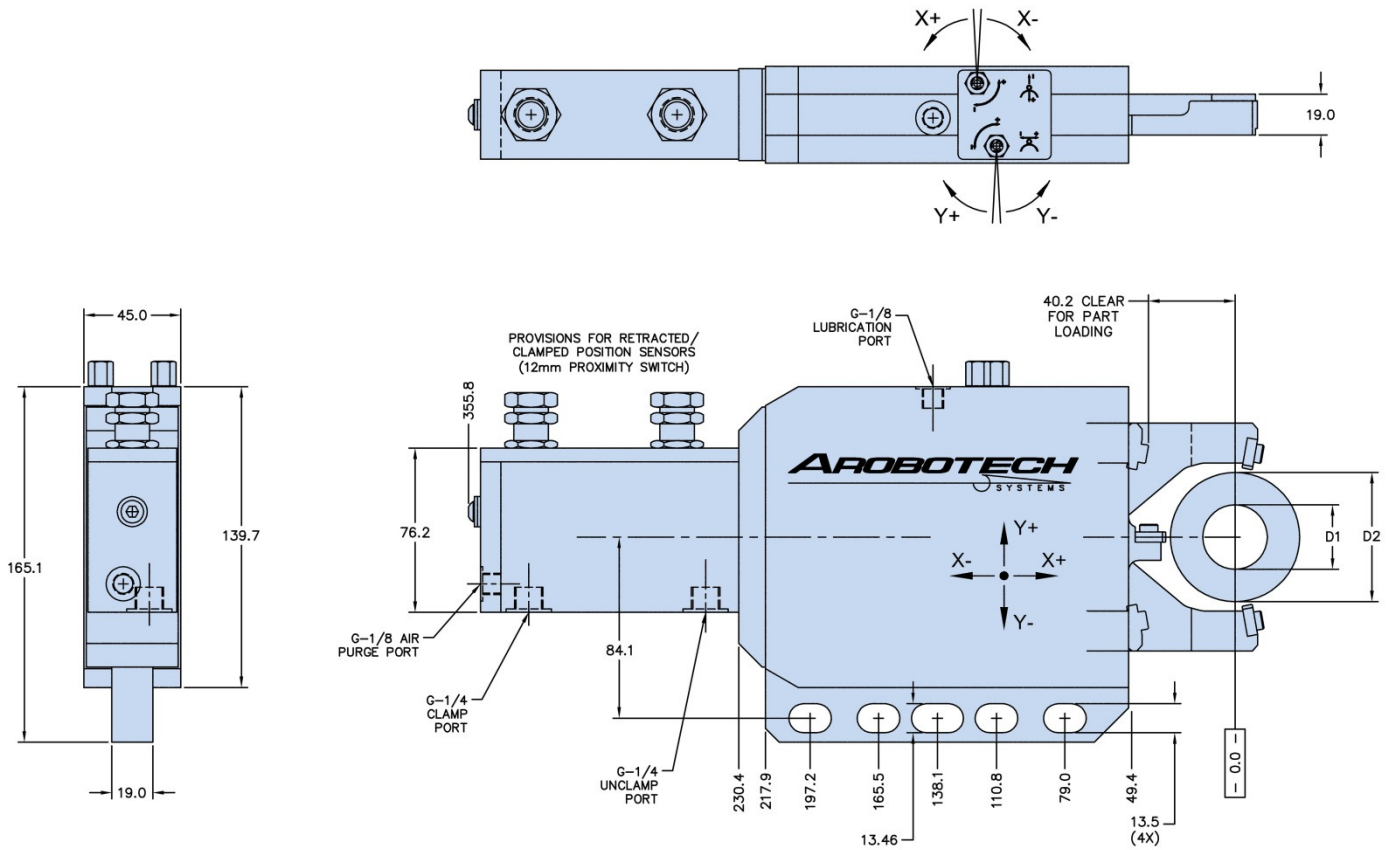

Pad Set			1	2
Minimum Clamp Diameter	D1	mm	20	30
Maximum Clamp Diameter	D2	mm	50	60

X-Axis Adjustment Range	mm	±0.22
Y-Axis Adjustment Range	mm	±0.07
Piston Area	cm ²	6.40
Cylinder Stroke	mm	72
Operating Pressure	bar	15 – 30
Maximum Pressure	bar	45
Air Purge Pressure	bar	0.3 – 0.5
Lubrication Volume	cm ³	0.04 – 0.06
Lubrication Frequency		Working Cycle (or every 6 minutes)
Repeatability	mm	±0.001
Mass	kg	10.2

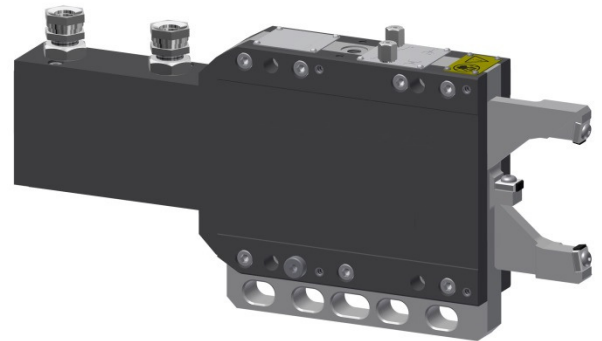

Included Features:

- * Arm Retraction For Part Loading
- * Fixed or Follow Down Operation
- * 2-Axis Centerline Adjustment
- * Position Feedback Sensors
- * Visible Zero Adjustment Screws
- * Lower Mounting Rail

Items Required To Use This Product:

- * Set of Wear Pads
- * Mounting Base