

SMART 2

Oil Lubrication Electro-Pump

User and Maintenance Manual

Warranty information

TABLE OF CONTENTS

1. INTRODUCTION
2. GENERAL DESCRIPTION
3. PRODUCT-MACHINE IDENTIFICATION
4. TECHNICAL SPECIFICATIONS
5. MACHINE COMPONENTS
6. UNPACKING AND INSTALLING THE MACHINE
7. INSTRUCTIONS FOR USE
8. TROUBLESHOOTING
9. MAINTENANCE PROCEDURE
10. DISPOSAL
11. ORDERING INFORMATION
12. DIMENSIONS
13. HANDLING AND TRANSPORTATION
14. OPERATING HAZARDS
15. PRECAUTIONS
16. WARRANTY INFORMATION
17. DECLARATION OF COMPLIANCE WITH STANDARDS
18. DROPSA LOCATIONS

Manufacturer	DropsA SpA
Product	SMART2
Year	2005
Certification	

1. INTRODUCTION

This *User and Maintenance Manual* refers to **SMART2 - Oil Lubrication Electro-Pump**.

You can find additional copies and newer revisions of this document from our website <http://www.dropsa.com>. Alternatively contact one of our Sales Offices.

This manual contains important information on health and safety issues for the personnel. It is recommended to attentively read this manual and carefully keep it in good condition so that it is always available to personnel requiring to consult it.

2. GENERAL DESCRIPTION

Oil lubrication pump **SMART2** has been designed for industry machine tools. The *electric gear-pump* was designed to work with *Single Line Injectors and Valves 33*.

SMART2 is available in two versions:

- **Manual SMART2**, manually controlled via the PLC of the machine tool;
- **Automatic SMART2**, automatically controlled via built-in **VIP05 controller**.

2.1 LUBRICATION CONTROL SYSTEM - PRINCIPLES OF OPERATION

AUTOMATIC SMART 2 operates on the principle of **intermittent lubrication** which involves the following three steps:

- **Prelube**
- **Lube (lube – wait)**
- **Standby**

2.1.1 PRELUBE

This step is made up of a set of cycles (max 999 cycles) during which the lubrication system runs a series of lubrication cycles (lubrication will be described in paragraph 2.1.2) necessary to vent air from the pump and check lubrication functions.

Prelube takes place:

- on POWER-ON;
- on RESET;
- Any time new parameters are set.

When *prelube* is set to "0", *Intermittent Lubrication* will only consist in the *lube – standby/standby - lube* phases (see *START mode*).

2.1.2 LUBE

This step is made up of a set of cycles (max 999 cycles) during which lubrication is carried out. Each cycle consists of two sub-cycles (*lube* and *wait*) and involves the monitoring of timers and/or inputs:

- during *lube*, system delivers lubricant to the lubrication points;
- during *wait*, a timer defines the wait time between two or more lube cycles or before the beginning of the standby phase (in case only 1 lube cycle was set).

There are three types of lube:

- **TIMER**: Lubricant delivery is simply regulated by a timer;
- **PS**: Lubricant delivery is carried out only if the system is in pressure;
- **SEP**: Lubricant delivery is carried out only the system detects three changes in the position of the mechanical piston. The conditions of: *pressure-no pressure-pressure* (or *no pressure-pressure- no pressure*)

2.1.3 STANDBY

During this step lubrication system is idle until the next lubrication cycle. There are three ways to regulate standby:

- **TIMER**: a timer regulate system idling;
- **PULSE**: a pulse counter regulate system idling;
- **BOTH**: both a timer and a pulse counter regulate system idling. The type of standby will depend on which of these two events will start first.

3. PRODUCT-MACHINE IDENTIFICATION

Machine identification yellow label is located on the front side of the reservoir and contains product serial number, input voltage and details of the operating parameters.

4. TECHNICAL SPECIFICATIONS

4.1 General technical specifications

Lubricant	Mineral Oil
Lubricant Viscosity at usage temperature	68 ÷ 320 cSt (320 ÷ 1480 SUS)
Working Temperature	+5°C ÷ + 60°C (+41°F ÷ +140°F)
Storage Temperature	- 20°C ÷ + 60°C (-4°F ÷ +140°F)
Working Humidity	90% max
Mechanical Protection Grade	IP-55
Sound Pressure Level	<70 dB (A)

4.2 Electric gear pump

Voltage	110V/50Hz	110V/60Hz	230V/50Hz	230V/60Hz
Power absorption	162W	155 W	150W	148W
Nominal current	1.48A		0.69A	0.70A
Pump flowrate	180 cm ³ /min (10.98 cu.in.)/min	220 cm ³ /min (13.42 cu.in.)/min	180 cm ³ /min (10.98 cu.in.)/min	220 cm ³ /min (13,45 cu.in.)/min
Maximum Pressure	30 bar (411psi)			
Reservoir Capacity	3 litres (0.66 gals)			
By-pass Calibration	25 bar (367.5 psi)			
Pressure-Switch calibration	18 bar (264.6 psi)			
Insulation Class	B			
Rotation direction	Clockwise			
Revolutions/min	2900	3500	2900	3500
Max working time in continuous	2 minutes			
MIN STANDBY time	5 times MIN setup time			



NOTE: pump output is energized.

5. MACHINE COMPONENTS

The following main components are assembled to the **baseplate**:

- **A reservoir**, made of transparent plastic material;
- **An electric gear-pump**, with high performance and minimum power consumption;
- **A SAMBA level sensor**, which indicates lubricant minimum level via a **N.O. electric contact** (reservoir empty). **To reverse N.O. to N.C., please contact Dropsa Eng. Dept.;**
- **A pressure gauge**;
- **A N.O. Pressure-switch**, which detects *system in pressure*;
- **A printed circuit for user connections** (see 6.4.2)

5.1 MANUAL SMART2

The electronic board, located under the cover of manual SMART2, allows pressure-switch and electric level contact management both independent and serial.

On the front panel there are:

- ❑ Push-button for manual control, “MANUAL”;
- ❑ LED indicator for “PUMP ON”. (Green, normally off)



5.2 AUTOMATIC SMART2

VIP05 Controller, located under the cover of automatic SMART2, allows pump total autonomy both in cycle times, alarms or checks.

On the front panel there are:

- ❑ LCD display 16x2 types;
- ❑ Push-buttons: three for control/management and one RESET button.
- ❑ LED indicator for “POWER ON” (Green, always on)



6. UNPACKING AND INSTALLING THE PUMP

6.1 UNPACKING

Once a suitable location has been found to install the unit, remove the pump from package. Check the unit has not been damaged during transportation or storage. No particular disposal procedures are necessary as package materials are no dangerous for health or environment. However, package should be disposed of in accordance with regulations that may be in force in your area or state.

6.2 INSTALLING THE PUMP

- In order to facilitate any maintenance intervention, to avoid unnatural posture for personnel during machine operation or the possibility of sustaining impacts, install the machine in a comfortable and easy-to-reach location.
- Allow sufficient space for the installation, leaving minimum 100 mm (3.9 in.) around the unit.
- Do not install the unit in aggressive or explosive/inflammable environments or on vibrating surfaces.
- To install the pump, use only the supplied bracket provided with two holes for Ø6 mm (Ø 0.2 in.) screws (see *Dimensions, ch. 12*).

6.3 HYDRAULIC CONNECTION

Connect **SMART2** to the system via the hydraulic connection located on the baseplate, on the right side of the pump: standard thread ¼ BSP.

6.4 ELECTRIC WIRING

6.4.1 ELECTRIC DIAGRAM

Here follows the general electric diagram for both automatic and manual **SMART2**:

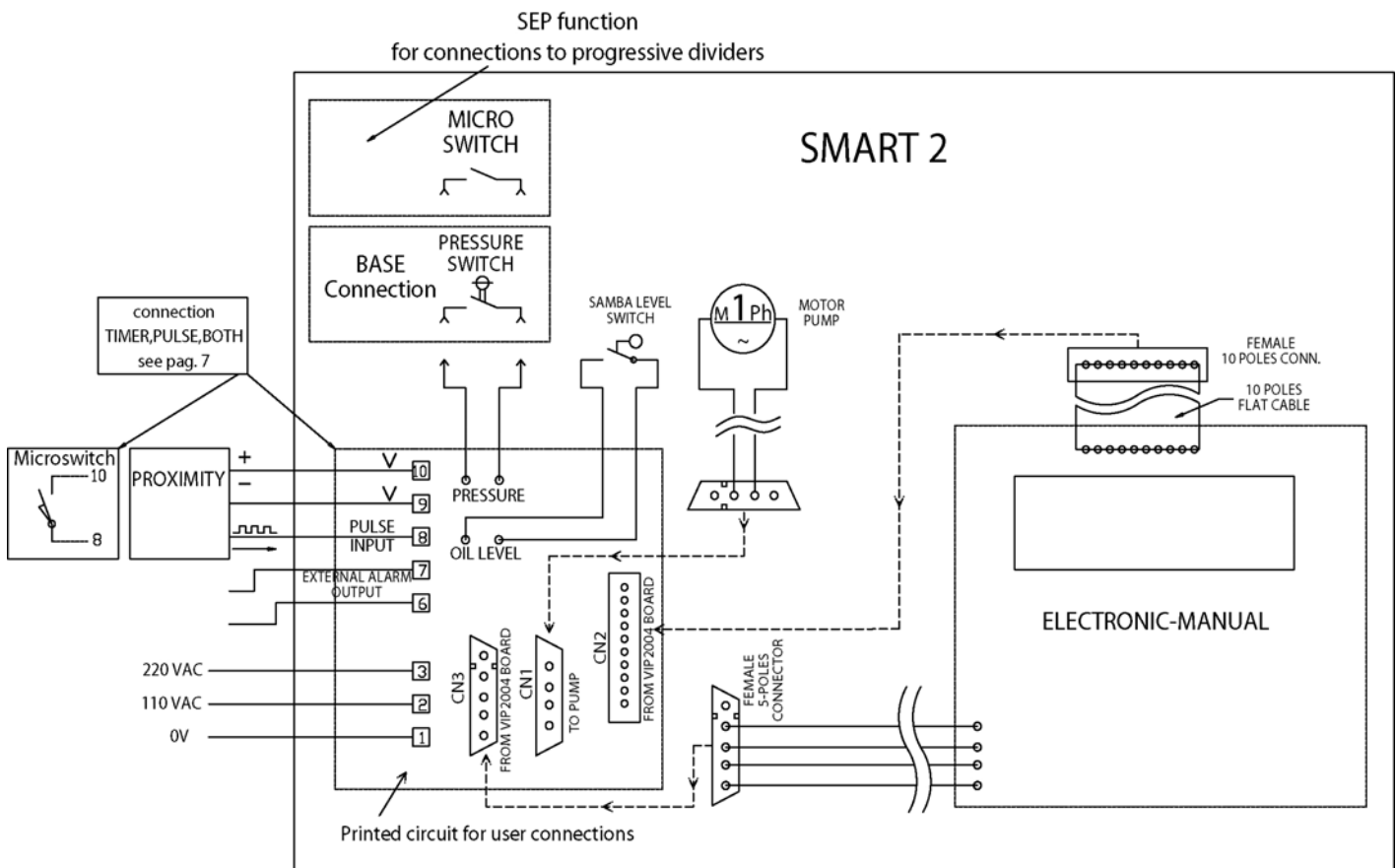

NOTICE: Pressure can be monitored by a micro-switch or a NPN/PNP proximity sensor.

6.4.2 USER CONNECTIONS

The following picture shows the printed circuit for user connections, where the user has to connect power supply and external outputs for the correct functioning of both automatic and manual SMART2. For details about connections, please refer to special paragraphs. **(Printed circuit serigraphy only refers to automatic SMART2. For the manual version there is a white label as showed in Fig. 2)**

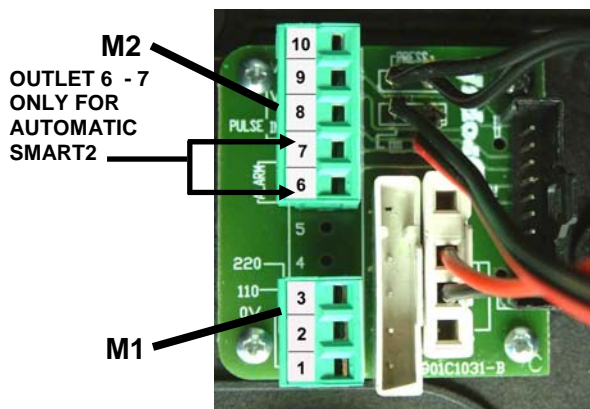

Fig. 1
Automatic version

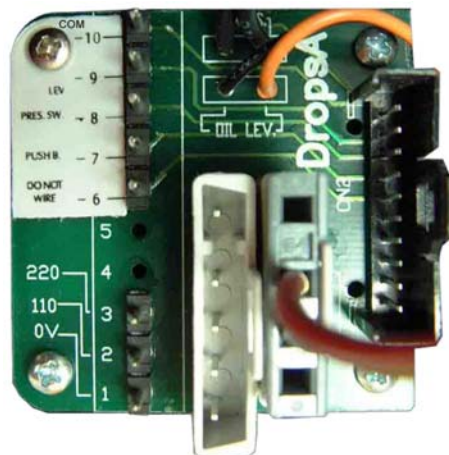
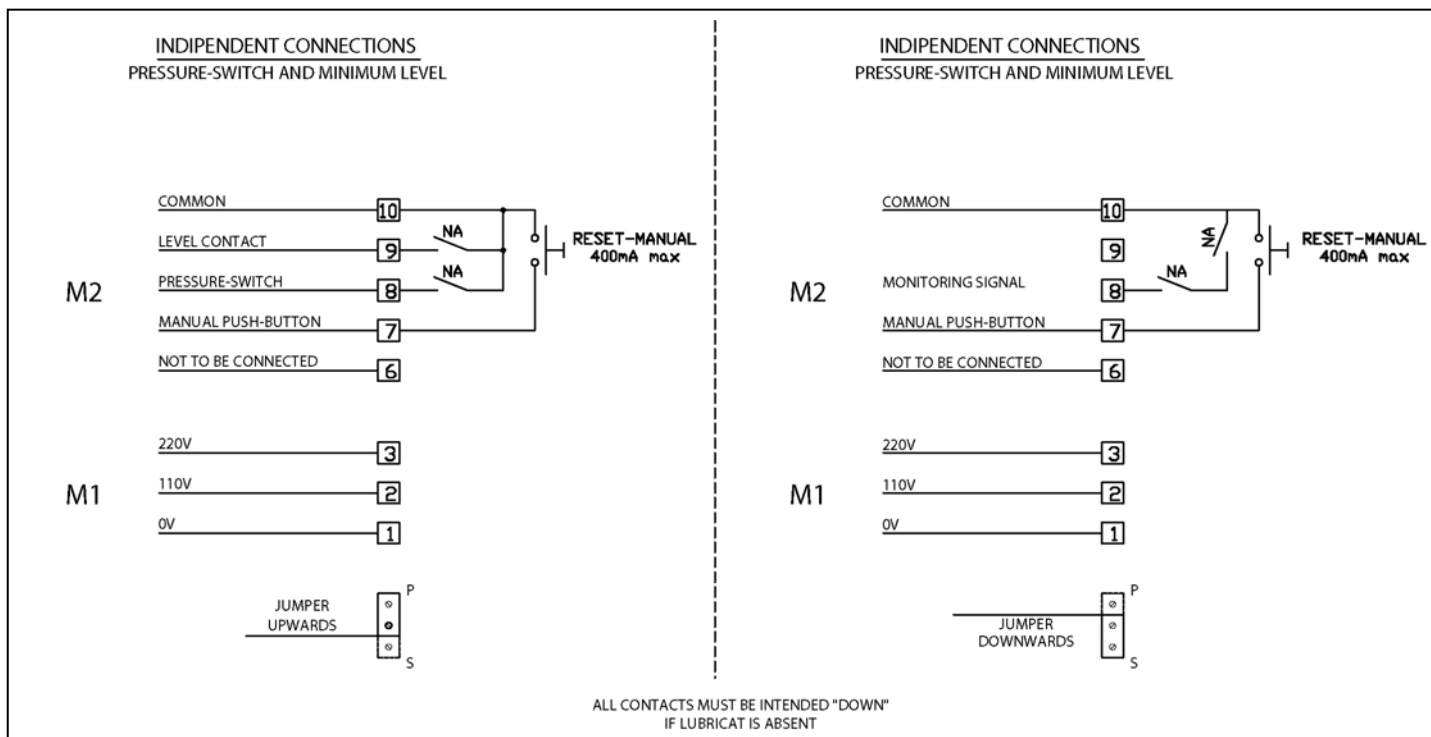

Fig. 2
Manual version

6.4.3. CONNECTIONS FOR MANUAL SMART2

Here follows user connections for power supply (terminal M1), pressure-switch and electric level contact (independent or serial), and the manual push-button (terminal M2). Furthermore, it is also shown how to change the type of connection (independent or serial) for the pressure-switch and electric level contact, by acting on the jumper located on the electronic board of *manual SMART2*.



6.4.4 CONNECTIONS FOR AUTOMATIC SMART2

Here follows user connections for power supply (terminal board M1), external alarm (terminals 6-7) and proximity sensor or micro-switch (terminals 8-9-10). These last terminals have the function of stopping the timer or to register the the pulse in order to define che standby duration. (See table A).

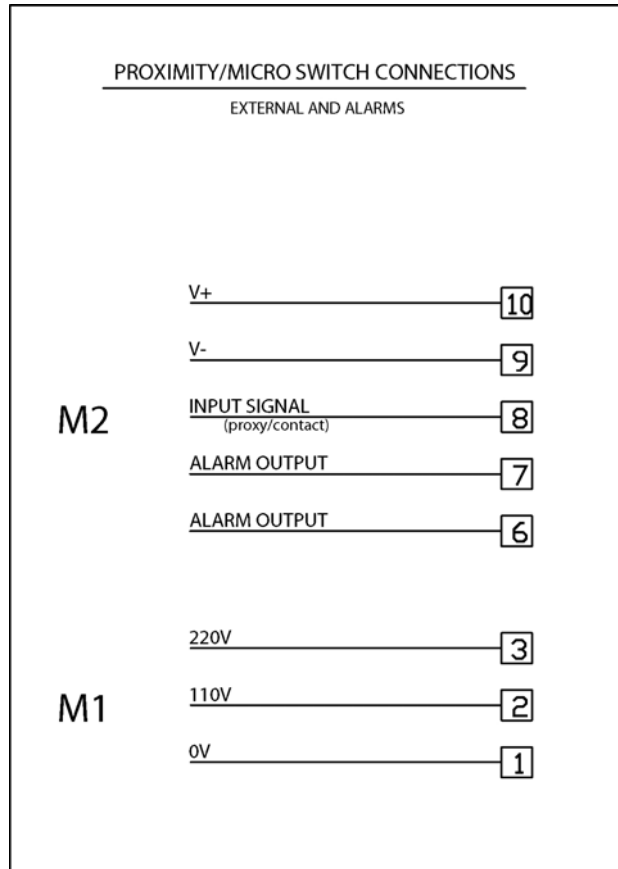

Input/output electrical specifications:

Power	See: 4.1 General technical specifications
Input signal	PNP proximity or N.O. free contacts input.
Alarm Output	Free contact: 250VAC –150 mA 125VAC/110VDC –300 mA 30VDC –1A

Table A

MODE	FUNCTION
STAND BY TIMER	Stops the timer for standby duration
STAND BY PULSE	Decrements the pulse counter that defines standby duration (this function doesn't stop the timer)
STAND BY BOTH	Decrements the pulse counter that defines standby duration (this function doesn't stop the timer)

6.4.5 POWER-SUPPLY SWITCH AND VARIABLE RESISTOR

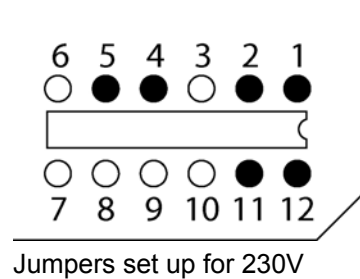
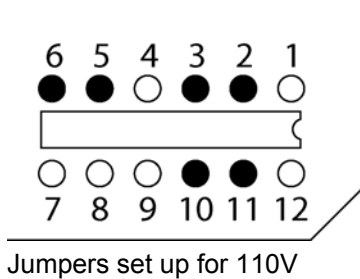
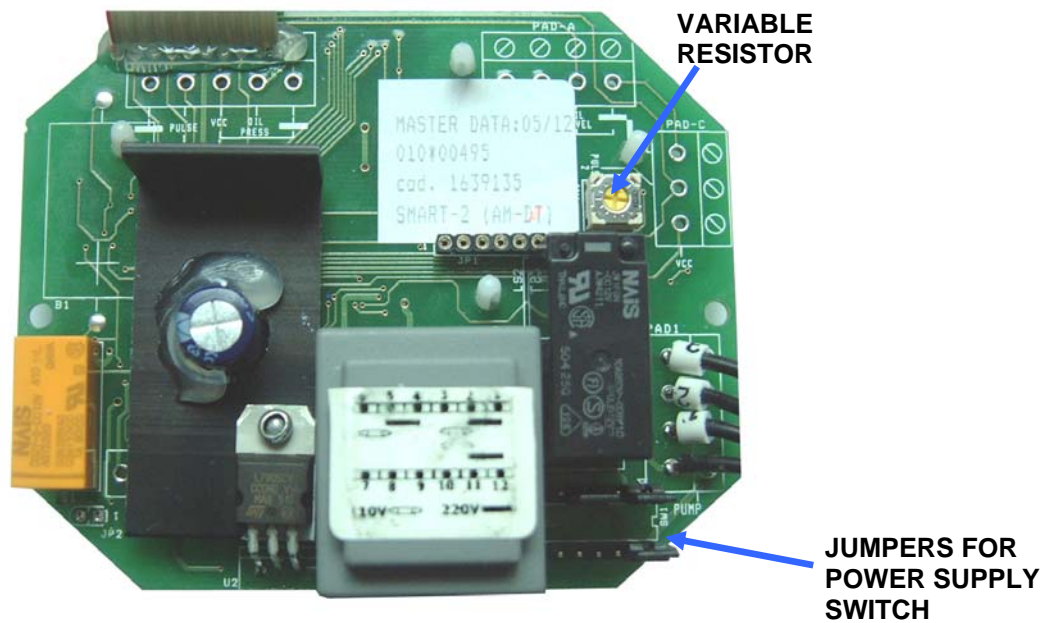

 **WARNING:** *Jumpers set up only refers to electronic board.*

VARIABLE RESISTOR

It allows to regulate display brightness.

 **WARNING:** Each time a powerfailure occurs, Date and Time are reset. It is recommended to setup Date and Time.

6.4.6. PRECAUTIONS TO BE TAKEN DURING CONNECTING PROCEDURE

- ⇒ Prior to any operation, verify the voltage of the machine on the product label.
- ⇒ In order to prevent dangers of electric shocks due to direct or indirect contact with the energized parts, electrical power supply line must be protected by a suitable magneto-thermal circuit breaker with an intervention threshold of 0.03 Ampere and 1 second minimum operating time. Circuit breaker power must be ≤ 10 kA and nominal power $I_n \geq 4$ A.

 **At the end of all connecting operations, make sure that pipes and wires are safe from impacts and carefully fixed.**

7. INSTRUCTIONS FOR USE

7.1 Manual SMART2

When the unit is equipped with the manual system, located on the frontal side panel you find the *PUMP-ON indicator* which is on when the pump is operating. Remote control is via external timer or PLC.



WARNING: *Manual control device (reset button) connects the common signals to a line that can be used as remote indication to PLC (or to another control system). It can be used, for instance, as indication to restart the lube cycle or to cancel an error on the pump. Max power absorption of 400mA.*

7.2 Automatic SMART2

When the unit is equipped with an automatic control, all the pump functions and checks are carried out through the built-in **VIP05** controller, alarms and external signals included. Timers are also controlled by the system. For details about machine operation, please refer to par. 7.4.

7.3 Machine operations

7.3.1 Prior to machine start-up

- Verify the unit is undamaged.
- Check that hydraulic and electric connections have been carefully carried out.
- Refill the reservoir with compatible lubricant.
- Verify the voltage: MAX 230VAC.

RESERVOIR REFILL

Use ONLY compatible lubricant and refill the reservoir by means of the oil refill plug provided with a filter. Do not pour lubricant directly into the reservoir without using this oil refill plug.

7.3.2 Machine start-up

In order to avoid damage to the machine, the unit must start operating at a minimum working temperature of +5°C (+41°F).

- Switch ON the unit (Green LED on)
- Verify unit start-up.
- Verify piping are air-bubble-free.
- Adjust pressure.
- Set-up machine parameters.
- Verify machine correct operation: pump must carry out lubrication correctly and according to parameters setup.

AIR VENTING

Pump well-functioning is not affected by presence of air in the system. However, it is advisable to vent air by starting the pump until lubricant comes out air-bubbles-free. (It is recommended to avoid pump operation when lubricant is below the minimum level).

PRESSURE REGULATION

Pressure can be verified via pressure gauge. It is possible to regulate pressure by acting on the screw located on the frontal side of the baseplate.

- ⇒ To increase pressure: turn the screw clockwise.
- ⇒ To decrease pressure: turn the screw anticlockwise.



In case of doubts as to correct machine functioning, it is recommended to contact our Eng. Dept. to request testing procedures.

7.4 SMART2 with built-in VIP05 controller operation

7.4.1 Typical working session

Notice: prelube is always carried out according to prelube cycles set-up: if prelube cycles = '0', no prelube is run and the system will start operating either in standby or lube according to the pre-set start mode.

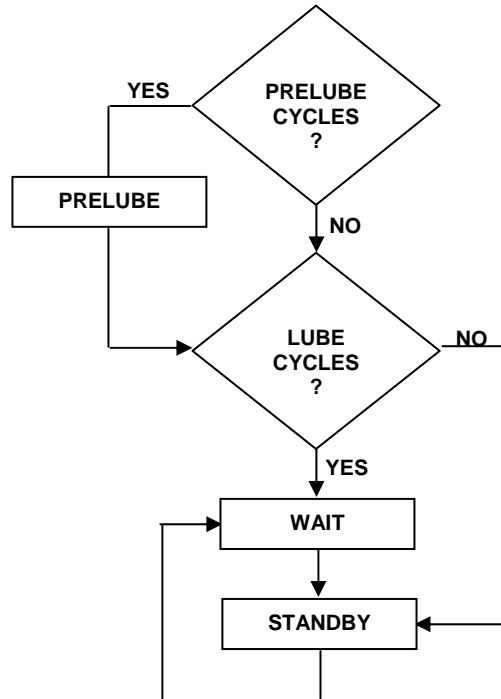

7.4.2 Typical system start-up

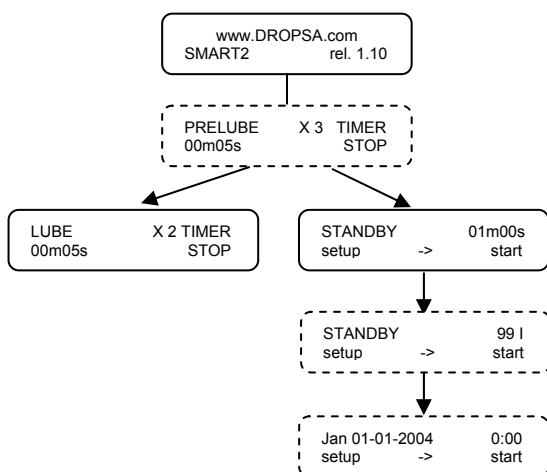

PRELUBE will be carried out only when prelube cycles are set ($PRELUBE \neq 0$).

Whether prelube has been completely carried out ($PRELUBE \neq 0$) or no prelube was set ($PRELUBE = 0$), **LUBE** or **STANDBY** will start (see start mode).

During standby, you can also see **date** and **time** when the function is enabled (see setup).

7.4.3 Setup session

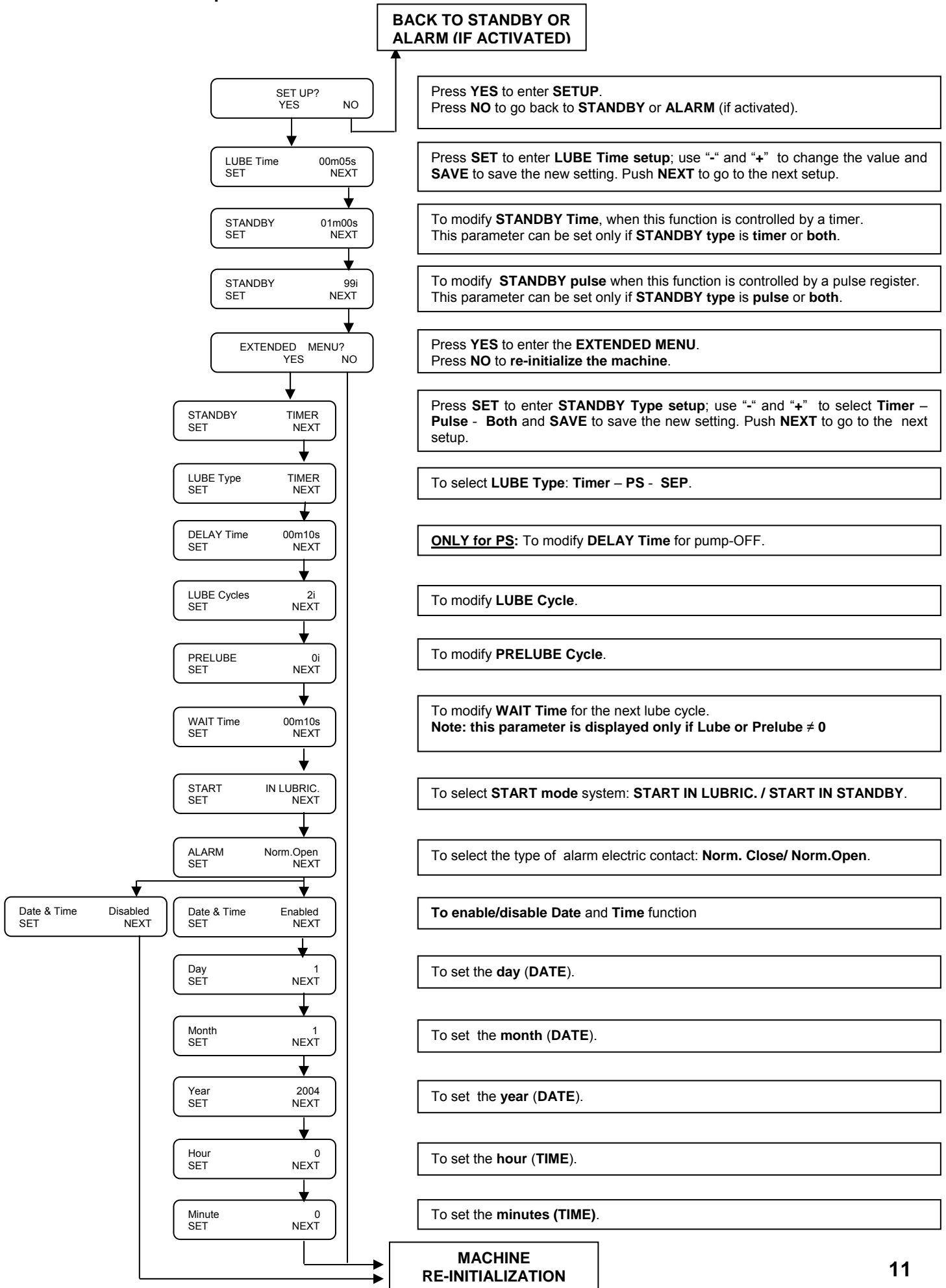

7.4.4 Operative parameters

Parameter	Description	Operative range	Dropsa setting
LUBE	Timer	A timer defines lube duration	00m01s ÷ 4m59s
	PS	Lube starts when system is in pressure (Pressure is monitored by a pressure-switch)	10s ÷ 99 min.
	SEP	A proximity sensor detects the changes of position of the piston: after three changes a lube cycle is completed (*)	
STANDBY	Timer	A timer defines standby duration (system idle)	01m00s ÷ 999h59m59s
	Pulse	A pulse register defines standby duration (system idle)	1i ÷ 9,999,999i
	Both	Standby duration (system idle) is defined by both standby timers (timer and pulse), whichever occurs first.	See Standby Timer and pulse 01m:00s 99i
STANDBY	It allows to choose the type of standby.	Timer Pulse Both	Pulse
Lube type	It allows to choose the type of standby.	Timer PS SEP	PS
DELAY TIME (FOR PS ONLY)	A timer defines the duration of PUMP ON (time lag for pump OFF) once the system goes in pressure	01s ÷ 99 min.	00m:10s
LUBE Cycles	Number of lube cycles to be carried out by the system	01÷ 999	2
PRELUBE cycles	Number of prelube cycles, which will be carried out before the lube cycles	1÷ 999	0
WAIT Time	A timer defines the duration of a <i>pause time</i> between each lube process. <i>ONLY for 'LUBE type: SEP': Set 00m00s for continuous service</i>	01s ÷ 16m39s	01m:00s
START MODE	It allows to choose how to start the working session	START IN LUBRIC. START IN STANDBY	START IN LUBRIC.
Alarm	It allows to choose the type of alarm electric contact	Norm. Open Norm. Close	Norm. Open
Date & Time	It allows to enable/disable Date & time display and setup	Enabled/Disabled	Enabled
Day	It allows to set the day	1-31	1
Month	It allows to set the month	1-12	1
Year	It allows to set the year	2000÷2099	2000
Hour	It allows to set the hour	0-23	0
Minute	It allows to set the minutes	00-59	00

(*) Please see the Electric Diagram at page 5

8. TROUBLESHOOTING



WARNING: *This unit can be opened and repaired by Dropsa personnel only*

The following diagnostic table indicates the main anomalies which may be encountered, the probable causes and possible solutions. **If you cannot solve the problem, do not attempt to disassemble the unit, but contact the Engineering Department of DROPSA S.p.A.**

8.1 PUMP DIAGNOSTICS (MANUAL AND AUTOMATIC SMART2)

ANOMALY	PROBABLE CAUSE	SOLUTION
Pump does not deliver lubricant. Pump does not deliver the fixed amount of lubricant	<ul style="list-style-type: none"> Pump draws off air because the reservoir is empty. 	→ Refill the reservoir and vent air from the system.
Pump delivers oil at an improper pressure	<ul style="list-style-type: none"> Loosened inner fittings. 	→ Retighten all the fittings. Be sure there are no Leakages.
	<ul style="list-style-type: none"> Wear of the pump. 	→ Replace the pump.
	<ul style="list-style-type: none"> Wrong calibration of the by-pass valve. 	→ Install a pressure gauge to adjust by-pass at the proper pressure.
The system stays in pressure at the end of the lube cycle	<ul style="list-style-type: none"> Vent valve damaged or dirty. 	→ Inspect and clean the valve. Replace it, if necessary.

8.2 VIP05 CONTROLLER ALARMS (AUTOMATIC SMART2)

When an alarm occurs, an external signal is ON. The display will show one of the following alarms for two seconds:

ALARM 01 - TIMER FAULT	Internal process error during <i>lube by timer</i> .
ALARM 02 - PX VENT FAILED	At the beginning of <i>lube by PS</i> : it was detected that the system has not vented air.
ALARM 04 PS - PRESSURE ALARM	During <i>lube by PS</i> , it was detected that the system never goes in pressure.
ALARM 06 PS - PRESSURE LOSS	During <i>lube by PS</i> , even though the pump is operating, the system loses pressure.
ALARM 08 PS - GENERAL FAULT	Internal process error during <i>lube by PS</i> .
ALARM 09 SEP - CYCLE TIMEOUT	During <i>lube by SEP</i> : the sensor cannot detect one or all the changes of position of the piston.
ALARM 10 SEP - GENERAL FAULT	Internal process error during <i>lube by SEP</i> .
ALARM 11 - LOW LEVEL	The Samba Level Sensor detected low level. Refill the reservoir.

8.3 RESTART/RESET the system

Once one of the above alarm status occurs, another display will be shown:

For example:



There are two ways to restore machine operating:

- ⇒ By pressing **setup** (left push-button), the system will enter the setup session to modify, at any rate, parameters and re-start the machine.
- ⇒ By pressing **reset for two seconds** (right push-button or RESET button), the system will be reset and the machine will be re-initialized and will operate according to the last saved data setup.

9. MAINTENANCE PROCEDURE



WARNING: *Prior to any maintenance, be sure that the power and the hydraulic supplies are off and there is no residual pressure in the main/branch pipe.*



NOTICE: The machine does not require any special tool for check or maintenance tasks. However, it is recommended the use only of appropriate and in good conditions tooling, protective devices (gloves) and clothing (626/94 and DPR 547/55) to avoid injury to persons or damage to machine parts.

SMART2 has been designed and manufactured to require the minimum maintenance. Anyway, it is recommended :

- To keep the unit clean and periodically to check pipe joints to readily detect possible leaks.



WARNING: *It is recommended the use of impurity-free lubricant.*

PERIODICAL MAINTENANCE

Inspection	Number of work cycles	Maintenance Procedure
Lubrication	1.000	-
Cleanliness of refill filter	4.000	Replace the refill filter, if necessary
Cleanliness of reservoir	6.000	Clean the bottom of the reservoir in case of impurities

10. DISPOSAL

During maintenance or disposal of the machine care should be taken to properly dispose of environmentally sensitive items. Refer to local regulations in force in your area.

When disposing of this unit, it is important to ensure that the identification label and all the other relative documents are also destroyed.

11. ORDERING INFORMATION

11.1 MANUAL SMART2

PART N°	DESCRIPTION
3600240	SMART2 ELECTRO-PUMP 110VAC/50 Hz
3600241	SMART2 ELECTRO-PUMP 110VAC/60 Hz
3600242	SMART2 ELECTRO-PUMP 230VAC/50 Hz
3600243	SMART2 ELECTRO-PUMP 230VAC/60 Hz

11.2 AUTOMATIC SMART2

PART N°	DESCRIPTION
3600210	SMART2 ELECTRO-PUMP 110VAC/50 Hz
3600211	SMART2 ELECTRO-PUMP 110VAC/60 Hz
3600212	SMART2 ELECTRO-PUMP 230VAC/50 Hz
3600213	SMART2 ELECTRO-PUMP 230VAC/60 Hz

11.3 SPARE PARTS

PART N°	DESCRIPTION
3132725	Control kit for automatic SMART2
3132726	Control kit for manual SMART2
3600903	Motor unit for SMART2 110V/50Hz (automatic and manual)
3600904	Motor unit for SMART2 110V/60Hz (automatic and manual)
3600905	Motor unit for SMART2 230V/50Hz (automatic and manual)
3600906	Motor unit for SMART2 230V/60Hz (automatic and manual)
6770033	Transparent reservoir 3 litres (0.66 gals)
3292053	Pressure gauge 60 bar (882 psi) 1/8" cone
6770070	Refilling Cap (for oil)
3130101	Refilling filter
3291048	Pressure-switch 18 bar (264.6 psi)
1655582	MIN level

12. DIMENSIONS

Weight: 4.00 Kg (8.8 lbs)

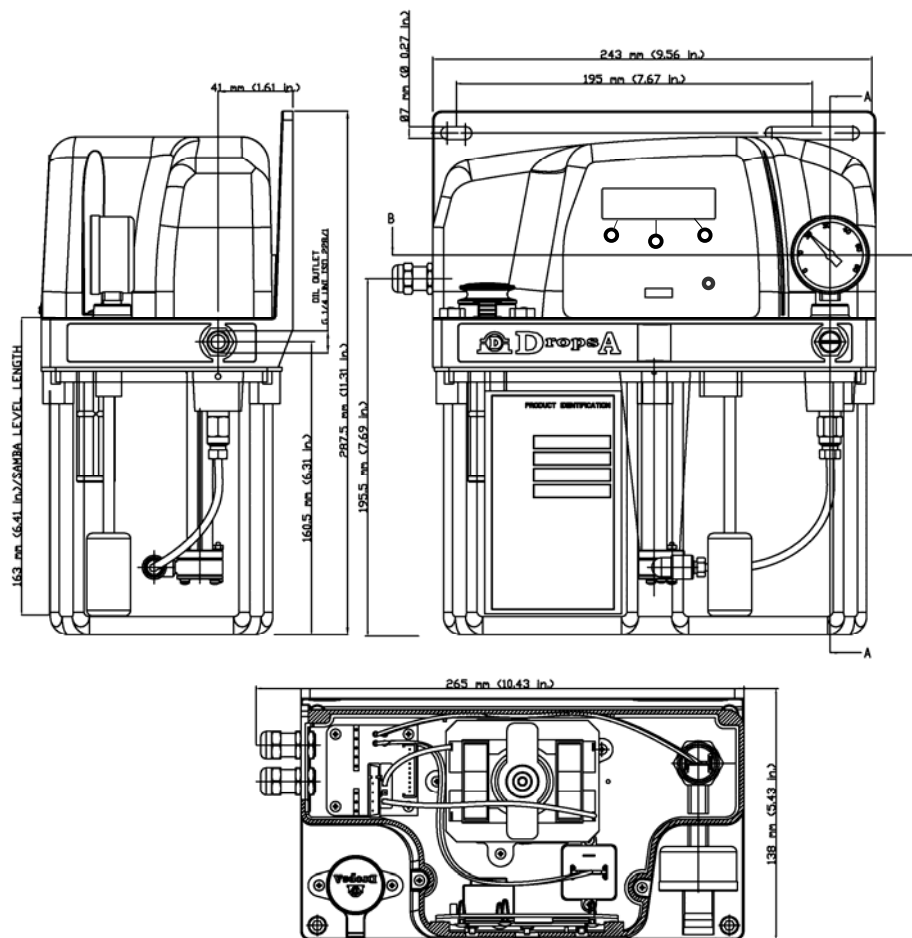

13. HANDLING AND TRANSPORTATION

Prior to shipping, the equipment is carefully packed in cardboard package. During transportation and storage, always maintain the pump the right way up as indicated on the box. On receipt check that package has not been damaged. Then, storage the machine in a dry location.

⇒ Due to machine contained weight and size, it is not necessary the use of material handling equipment. Anyway, we recommend to lift the equipment observing the right way up shown on the cardboard package.

14. OPERATING HAZARDS



WARNING: *It is necessary to carefully read about the instructions and the risks involved in the use of lubrication machines. The operator must know the machine functioning through the User and Maintenance Manual.*

Power supply

Any type of intervention must not be carried out before unplugging the machine from power supply. Make sure that no one can start it up again during the intervention. All the installed electric and electronic equipment, reservoirs and basic components must be grounded.

Flammability

The lubricant generally used in lubrication systems is not normally flammable. However, it is advised to avoid contact with extremely hot substances or naked flames.

Pressure

Prior to any intervention, check the absence of residual pressure in any branch of the lubricant circuit as it may cause oil sprays when disassembling components or fittings.

Noise

Pump does not produce excessive noise, less than 70 dB(A).

15. PRECAUTIONS

No particular operating hazards characterize the machine, except for the following precautions:

- ◆ Operator's contact with the lubricant in case of piping breaking/opening or during refill/maintenance. -> Protection against direct and indirect contact with the fluid must be provided by the user: *the operator must be provided with suitable individual protective clothing and devices (tit VIII – 626).*
- ◆ Use of incompatible lubricant. Main unauthorized fluids:



Fluids	Dangers
Lubricants containing abrasive components	Premature wear of pump
Lubricants containing silicon	Pump failure
Petrol – solvents – inflammable liquids	Fire – explosion – seal damage
Corrosive products	Pump damage - danger to persons
Water	Pump oxidization
Food Products	Contamination of the product

16. WARRANTY INFORMATION

All products manufactured and marketed by Dropsa are warranted to be free of defects in material or workmanship for a period of at least 12 months from date of delivery. Extended warranty coverage applies as follows:

Complete system installation by Dropsa: 24 Months

All other components: 12 months from date of installation; if installed 6 months or more after ship date, warranty shall be maximum of 18 months from ship date.

If a fault develops, notify us giving a complete description of the alleged malfunction. Include the part number(s), test record number where available (format xxxxxx-xxxxxx), date of delivery and installation and operating conditions of subject product(s). We will subsequently review this information and, at our option, supply you with either servicing data or shipping instruction and returned materials authorization (RMA) which will have instructions on how to prepare the product for return. Upon prepaid receipt of subject product to an

authorized Dropsa Sales & Service location, we will then either repair or replace such product(s), at our option, and if determined to be a warranted defect, we will perform such necessary product repairs or replace such product(s) at our expense.

Dropsa reserves the right to charge an administration fee if the product(s) returned are found to be not defective.

This limited warranty does not cover any products, damages or injuries resulting from misuse, neglect, normal expected wear, chemically caused corrosion, improper installation or operation contrary to factory recommendation. Nor does it cover equipment that has been modified, tampered with or altered without authorization.

Consumables and perishable products are excluded from this or any other warranty.

No other extended liabilities are stated or implied and this warranty in no event covers incidental or consequential damages, injuries or costs resulting from any such defective product(s).

The use of Dropsa product(s) implies the acceptance of our warranty conditions. Modifications to our standard warranty must be in writing and approved by Dropsa.

17. DECLARATION OF COMPLIANCE WITH CE STANDARDS

18.DROPSA LOCATIONS



Dropsa USA Inc.
50679 Wing Drive
Utica, Michigan 48315 - USA
Tel: (+1) 586-566-1540
Fax: (+1) 586-566-1541
E-mail: salesusa@dropsa.com



Dropsa (UK) Ltd
Unit 6, Egham Business Village,
Egham, Surrey, TW20 8RB
Tel: (+44) 01784 - 431177
Fax: (+44) 01784 - 438598
E-mail: salesuk@dropsa.com



Dropsa S.p.A.
Via B. Croce,1
20090 Vimodrone (MI) Italy
Tel: (+39) 02 - 250.79.1
Fax: (+39) 02 - 250.79.767
E-mail: sales@dropsa.it (Export)
E-mail: vendite@dropsa.it (National)



Dropsa GmbH
Volmerswerther Strasse 80
40221 Dusseldorf 1, Deutschland
Tel: (+49) 0211/39 4011
Fax: (+49) 0211/39 4013
E-mail: sales@dropsa.de



Dropsa France
23, Av. des. Morillons
Z.I. des Doucettes
91140 - Garges Les Gonesse
Tel: (+33) 01 39 93 00 33
Fax: (+33) 01 39 86 26 36
E-mail: sales@dropsa.com



Dropsa do Brazil
Rua Sobralia 171 Santo Amaro
Sao Paulo, Brazil
Tel: (+55) 011-5631-0007
Fax: (+55) 011-5631-9408
E-mail: salesbr@dropsa.com



Polydrop S.A.
Av. Fabregada 26 - Pje Est.2
08907 L'Hospitalet de Llobregat
Barcelona, Spain
Tel: (+34) 93 260 22 50
Fax: (+34) 93 260 22 51
E-mail: sales@dropsa.it



Dropsa Australia Pty.
C20/148 Old Pittwater Road
Brookvale NSW 2100
Tel: (+61) 299 386 644
Fax: (+61) 299 386 611
E-mail: sales@dropsa.com



Web site: <http://www.dropsa.com> - E-mail: sales@dropsa.com